

## Another Macro Repair Job

By Fritz Schulze

It was in response to an advertisement in a local newspaper that I decided in 1973 to buy a Bushnell 8x30 Broadfield Compact binocular for \$ 115, at a time when Japanese prism binoculars were offered for \$ 25. The all metal binocular is no lightweight: it weighs in at 526g and feels heavy and solid (Fig.1). It features central internal focusing, roof edge prisms, and coated optics (Fig. 2). I figured that at that price I could expect adequate quality. Indeed, the instrument did not disappoint me, it performed most satisfactorily **until** in 1996 our 6 year old grandson with his inquisitive fingers dropped it! Following Murphy's Law it fell so to do the most damage: on an eyepiece, cracking the internal focusing mechanism.

This particular binocular has an internal scissor-like mechanism that moves the eyepieces simultaneously in and out controlled by a central knob (Fig. 3). From the central focusing spindle two symmetric levers, Bushnell calls them "bridges", reach out and carry the eyepiece sleeves which, in turn, slide in the body tubes. This means that the lateral friction in the tubes exerts considerable forces on these levers which have two weak points A and B at each end (Fig.1). And that is exactly where one of them broke.

My motto has always been *Waste not, want not* and don't throw anything out that can be fixed, particularly not an otherwise fine pair of binoculars. My first attempt to repair the damage was a twofold one: at one end of the broken lever I inserted a small pin for strength and cemented the fracture with epoxy (Fig.5). At the other end I reattached the eyepiece sleeve with two angle brackets screwed on (Fig.10). This repair had one drawback: the thickness of the epoxy, about 0.3mm, which I did not allow for, displaced the respective eyepiece sleeve outward, causing some friction in the tight fitting bodytube. Still, the repair held until about half a year ago when it finally gave in.

My second attempt using UV-hardened epoxy didn't even last beyond the reassembly. Obviously another approach was called for. I decided to take a page out of the doctor's book and "splint" the broken lever with sheet metal. In my *Waste not, want not* box of odd pieces of sheet metal of all sorts I found a black aluminum frame of 0.3mm thickness for 6x9cm films (Fig.6), just about right. By omitting an original brass washer of 0.25mm thickness (and hoping that generous

lubrication of the resulting aluminum on aluminum bearing would guarantee year-long use of the binocular's PD adjustment with its limited range) the lower splint would not add appreciatively to the construction specification (up and down range within the housing). The upper splint was of no negative influence.

To make the splints I clamped two pieces of aluminum doubled between pieces of hardwood, drilled first a 4mm hole, then the final 8mm one (Fig.9). Then, slipping the pieces back on the drill bit shaft and superimposing the broken bearing, I scribed the outline on the black aluminum sheet as well as the shape of the arms. With the help of a strong pair of scissors (don't laugh, a sturdy pair inherited from my mother!) I cut the required shape and finished it up with needle files and light sanding (Fig.8).

Meanwhile I had recemented the broken joint again. It was now strong enough for the subsequent handling. I threaded all again on the 8mm drill bit shaft and arranged some sort of clamping the assembly for the drilling of the hole for the rivet which I had machined from an aluminum nail (Fig.9). I had discarded the idea of using a screw, the thickness of the head and nut would have limited the sparse room available for the focusing movement. I drilled the hole for the 1.5mm dia. rivet, counter sunk it and hammered the rivet in. So far so good (Fig.11).

Final assembly proved the success of the ambitious repair effort. Everything worked fine (Fig.12). The optics was reinstalled, the diopter scale adjusted, the focus checked, and a great sigh of relief breathed. My binocular is now, hopefully, again good for another twenty years (but I won't be around to verify that!).

I might just add that disassembling the focusing mechanism of the binocular posed some problems. A variety of securing grub screws and large ring nuts that required special two-pin tools made the job not easy. Whether my DIY job will last remains to be seen.

PS: The drawings are only meant to illustrate the process, so are the measurements given.

Fritz Schulze

Canada



Fig. 1

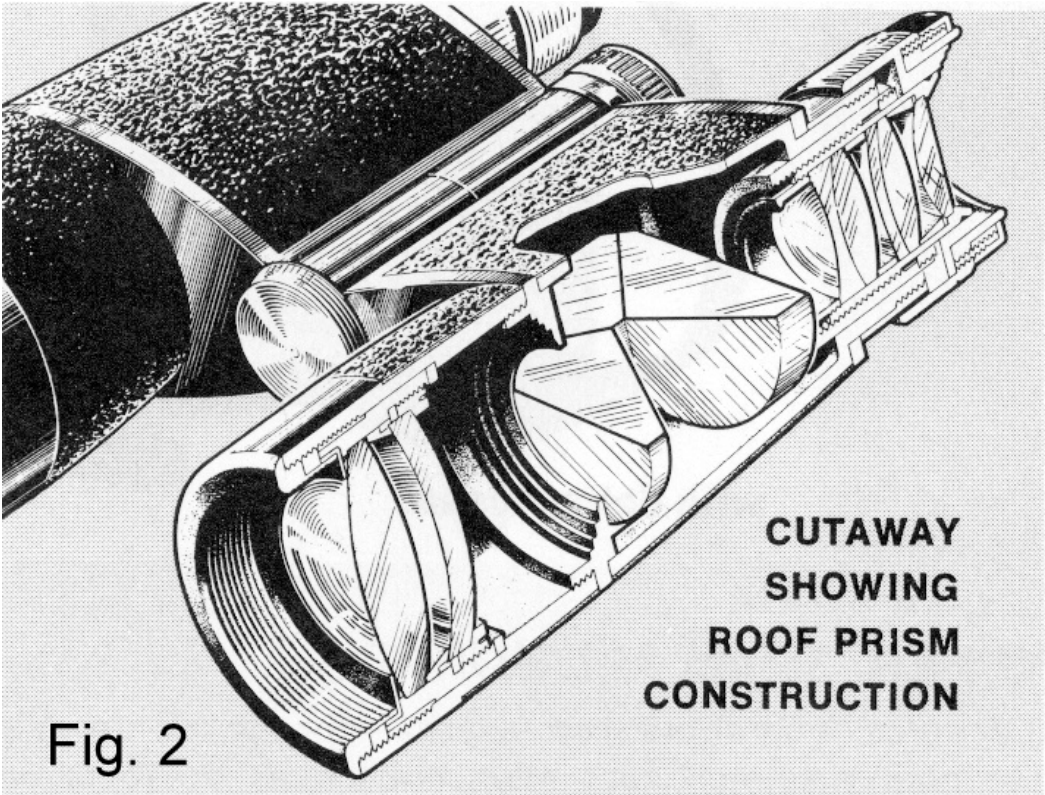

Fig. 2

Principle diagramme of mechanism

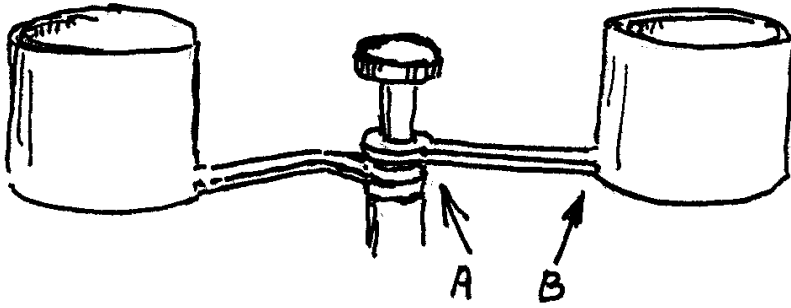
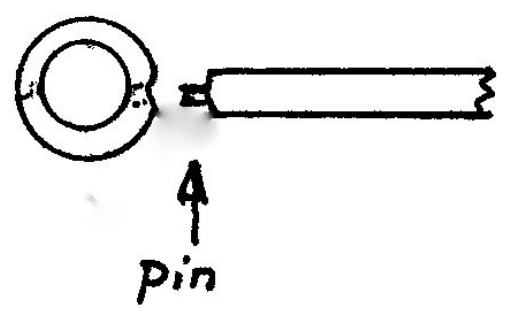
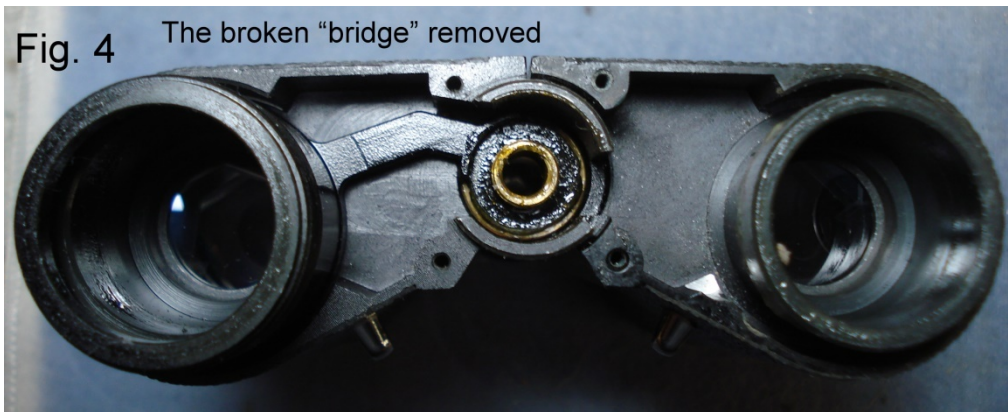

Fig. 3 Weak = rupture points



First repair (notice reinforcing pin)

Fig. 5



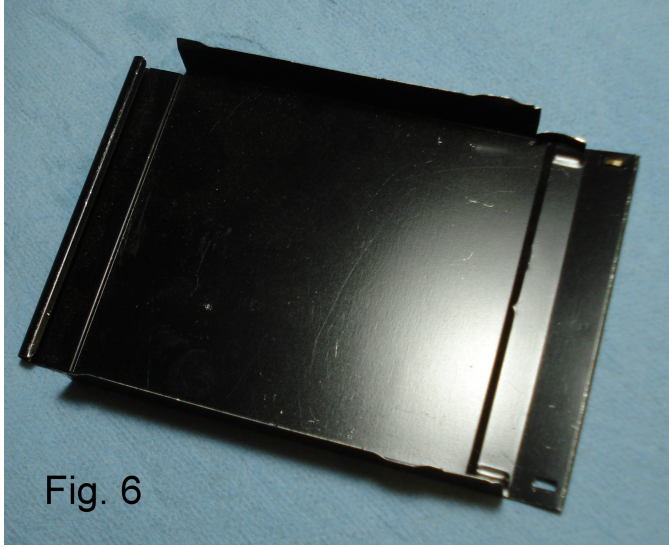

Fig. 6



The top splint

Fig. 7



Fig. 8

Ready for rivetting the splints

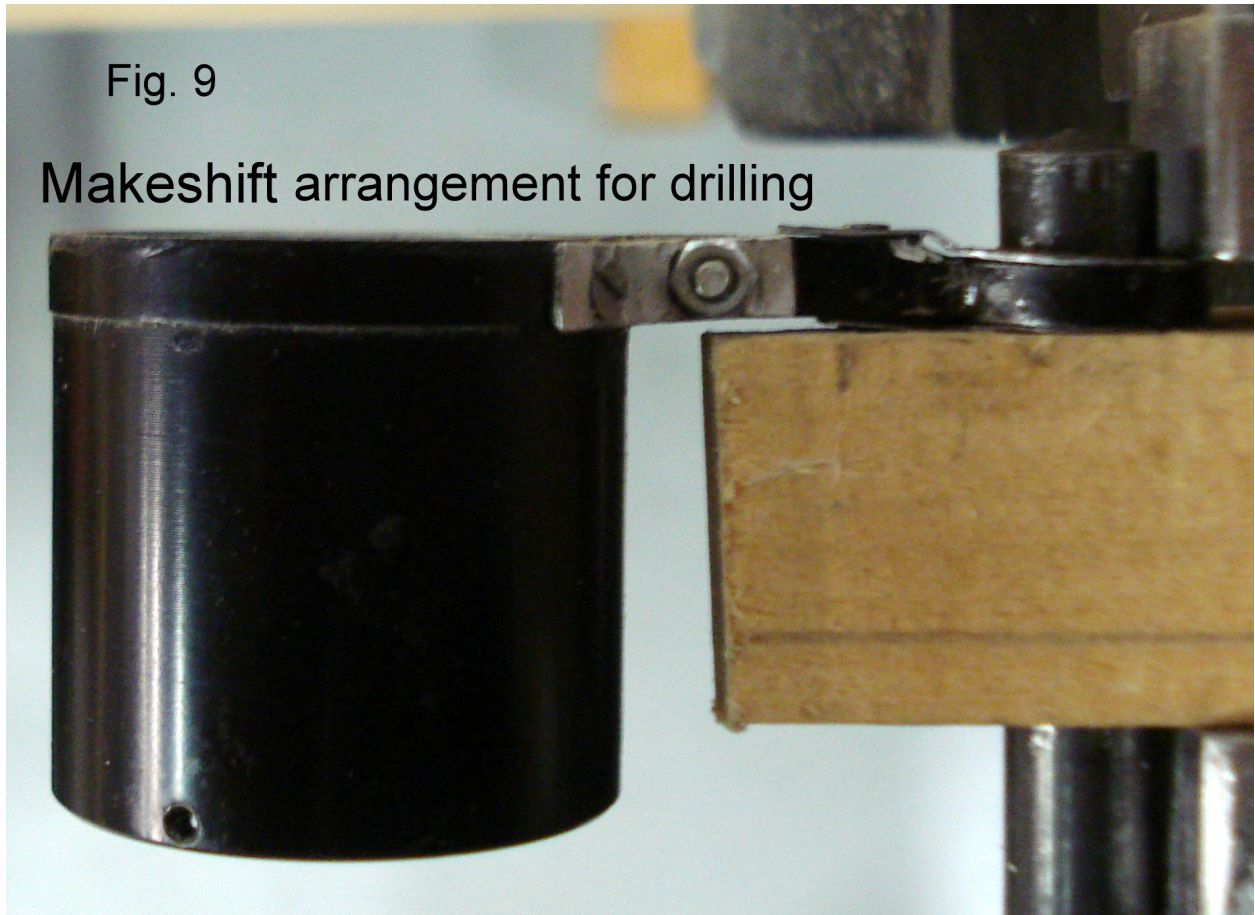

Fig. 9

Makeshift arrangement for drilling

Fig. 10

The two splints are in place



Fig. 11

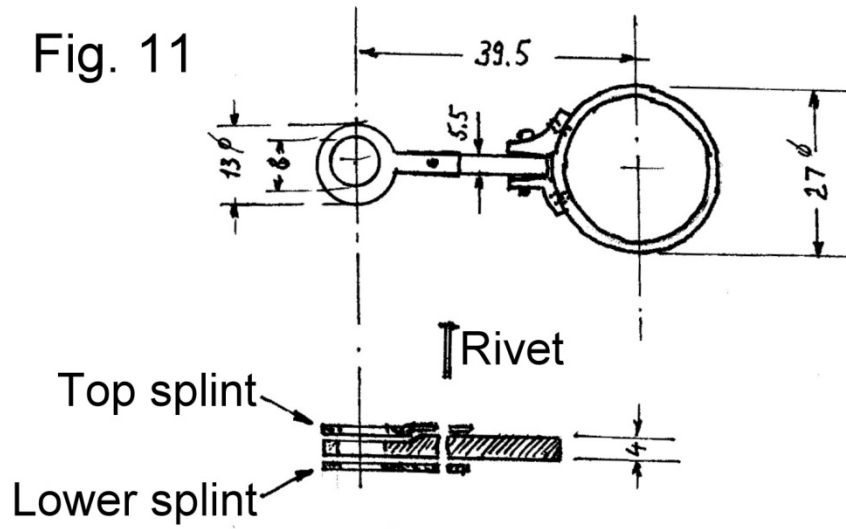

Details of final repair



## Fig.12

The repaired "bridge" re-installed



Comments to the author Fritz Schulze welcomed, email glenelly AT sympatico DOT ca.

Published in the February 2021 issue of *Micscape* magazine.

[www.micscape.org](http://www.micscape.org)